



# PRATT®

## 24" and Larger Butterfly Valves

### TABLE OF CONTENTS PAGE

General Information	2
Installation Instructions	3-4
Operation Instructions	4
Start-up Procedure and Maintenance	5
Troubleshooting	6
Replacement Procedure	7
Parts Information	8-9

**⚠ WARNING:**

1. Read all applicable directions and instructions prior to any maintenance, troubleshooting or installation.
2. Personnel involved in the installation or maintenance of valves should be constantly alert to potential emission of pipeline material and take appropriate safety precautions. Always wear suitable protection when dealing with hazardous pipeline materials.
3. Order parts from your local Pratt sales representative or directly from Henry Pratt Company. When ordering parts, please include the serial number located on the valve tag.

**NOTE:** "WARNING" and "CAUTION" messages (flagged with an exclamation symbol) indicate procedures that must be followed exactly to avoid equipment damage, physical injury, or death.

**HENRY PRATT COMPANY**  
Customer Service  
401 South Highland Avenue  
Aurora, IL 60506  
877.436.7977  
[www.henrypratt.com](http://www.henrypratt.com)  
[moreinfo@henrypratt.com](mailto:moreinfo@henrypratt.com)

# 24" and Larger Butterfly Valves

## General Information

### FUNCTIONAL DESCRIPTION

Round butterfly valve discs rotate 1/4 turns to provide tight shutoff in air or water pipelines. The valves can be used to regulate flow rate by positioning the disc between 15 and 90 degrees open.

#### Manually Operated Valve

Manually operated butterfly valves are powered with gear actuators, which convert multiple handwheel, chainwheel or nut input turns into 1/4 turn valve operation. The travel of the valve disc is limited by physical stops in the actuator housing.

**⚠ CAUTION: Forcing the handwheel, chainwheel or nut against the stops will not provide tighter shutoff of the valve and may damage the actuator. Only actuator adjustments will affect valve shutoff.**

#### Motor Operated Valve

Motor operated butterfly valves are powered with gear actuators, which convert multiple motor input turns into 1/4 turn valve operation. The travel of the valve disc is limited by limit switches in the motor housing and physical stops in the actuator housing. Valve shutoff is affected by limit switch and physical stop settings.

**⚠ CAUTION: Improperly set limit switches and/or physical stops may damage the motor and/or actuator.**



#### Cylinder Operated Valve

Hydraulically operated butterfly valves are powered with a gear box and double acting cylinder. The linear stroke of the cylinder is converted to 1/4 turn operation by the gear box. Auxiliary controls are provided to direct hydraulic power to the cylinder and to control the operating speed of the cylinder.

### INSTALLATION

#### General

Valves are a significant component of any piping system. Failure due to faulty installation, improper operation or maintenance in such systems could result in damage, down time and costly repairs. In buried underground installations, problems or malfunctions can result in extensive, costly unearthing operations to correct the problem. Many problems with valves can be traced to improper installation, operation, or maintenance procedures.

#### Unloading

Inspect valves on receipt for damage in shipment and conformance with quantity and description in the shipping notice and order. Carefully unload all valves to the ground without dropping using fork trucks or slings under skids. Do not lift valves with slings or chain around operating shaft, actuator, or through waterway. Instead, lift valves with eye bolts or rods through flange holes.

#### Storage

Whenever practical, store valves indoors. If not, protect valves and actuators from weather and accumulation of water, dirt, rocks and debris. When valves fitted with power actuators and controls are stored, energize electric actuator or otherwise protect electrical control equipment to prevent corrosion of electrical contacts due to condensation resulting from temperature variation. Do not expose rubber seats to sunlight or ozone for any extended period. Valves should be stored with the valve disc or closure member slightly open.

#### Inspection Prior To Installation

Make sure flange faces and joint sealing surfaces, body seats and disc seats are clean. Check bolting attaching actuator to valve for

loosening in transit and handling. If loose, tighten firmly. Open and close valve to make sure it operates properly and that stops or limit switches are correctly set so that the valve seats fully. Check that valve rotation direction is correct and close valve before installing.

#### Installation Instructions

The following items must be performed during installation to ensure proper function.

1. Carefully place valves into position avoiding contact or impact with other equipment, vault walls or trench walls.
2. Valves are to be installed in accordance with the General Arrangement Drawings furnished for the order.
3. Foreign material in a valve can damage the rubber seat when valves are operated. Be sure valve interiors and adjacent piping are clear of foreign material prior to mating valve to pipe joint.
4. Prepare pipe ends and install valves in accordance with the pipe manufacturer's instructions for the joint used. Do not deflect pipe/valve joint. Do not use valve and jack to pull pipe into alignment.
5. In plant piping, install so as to minimize bending of valve connection with pipe loading.
6. Make sure valve disc, when opened, will not contact pipe port. This is especially necessary on pipe with linings. Check manufacturer for minimum pipe I.D. required for clearance.

**⚠ CAUTION: It is recommended that valves be installed into piping system in accordance with AWWA M-11 in order to prevent any undue piping stress, deflection or bending that may affect the performance of the valve.**

**Valve disc without actuator may open or close at any time and cause injury to persons or damage to valve and other property. The shaft/disc clamping device when furnished is intended for temporary use during shipping, handling and valve installation only. Do not subject valve to flow conditions before actuator is mounted and tested for performance and clamping device is removed.**

Buried valves installed with valve boxes must be so installed that the valve box does not transmit shock or stress to the valve actuator as a result of shifting soil or traffic load.

When valves are installed in vaults, the vault design must provide space for purposes of repair. The valve operating nut should be accessible from the top opening of the vault with a tee wrench.

#### Mechanical Joint Installation

The successful operation of the mechanical joint requires that the plain end be centrally located in the bell and that adequate anchorage be provided where abrupt changes in direction and dead ends occur. The rubber gasket will seal more effectively if the surfaces with which it comes in contact are thoroughly cleaned (for example, with a wire brush) just prior to assembly in order to remove all loose rust or foreign material.

Lubrication and additional cleaning should be performed by brushing both the gasket and the plain end with soapy water or pipe lubricant just prior to slipping the gasket into the plain end and assembling the joint.

# 24" and Larger Butterfly Valves

## Installation (cont.) / Operation Instructions

### Testing

When rubber seated valves are used to isolate sections of line for test, it is important to realize that these valves are designed or factory adjusted to hold rated pressure only. Test pressure may cause leakage past the rubber seat or damage to the valve.

In order to prevent time lost in searching for leaks, it is recommended that excavations for

buried valves not be back-filled until after hydrostatic pressure tests have been made.

Seat leakage can occur due to foreign material in the line. If this occurs, open valve 5 – 10 degrees to get high velocity flushing action. Close and repeat several times to clear seats for tight shutoff.

Seat leakage can occur due to rotational shift in position of the disc with relation to the body seat.

Readjust closing stop in accordance with manufacturer's instructions.

### Records

Upon completion of installation, valve location, size, make, date of installation, number of turns to open, direction of opening and any other information deemed pertinent should be entered on Owner's permanent records.

## OPERATION

Do not permit use and operation of any valve at pressure above the rated pressure of the valve.

Do not exceed 300 ft-lb input torque on actuators with wrench nuts, 200 lb. rim pull input torque for handwheels or chainwheels. If portable auxiliary actuators are used, size the actuator or use a torque limiting device to prevent application of torque exceeding 300 ft-lbs. If an oversize actuator with no means of limiting torque is used, stop the actuator before valve is fully opened or closed against stops and complete the operation manually. Be sure to check actuator directional switch against direction indicated on wrench nut, handwheel or records before applying opening and closing torque.

If a valve is stuck in some intermediate position between open and closed, check first for jamming in the actuator. If nothing is found, the interference is inside the valve. In this case, do not attempt to force the disc open or closed since excessive torque in this position can severely damage internal parts. Contact the Pratt Service Department.

### Manual Actuator Function and Use

The manually operated butterfly valves are operated by rotating the handwheel, chainwheel, or nut. The actuator is equipped with gearing to convert the many turns into 1/4 turn operation. Inside actuator stops that limit the travel of the valve are pre-set at the factory. Forcing the handwheel, chainwheel, or nut will not cause the valve to shut off any tighter and may cause damage to the gearing.

### Cylinder Operator Function and Use

The cylinder operated butterfly valves are operated automatically by directing hydraulic pressure to either side of the power cylinder. Solenoid valves are used to direct the fluid to the cylinder ports based on electrical power signals. In cylinder actuators, the travel stops are in the cylinder so that full hydraulic pressure can be held on the cylinder at either end of travel.

### Motor Actuator Function and Use

The motor actuator is designed to open and close the valve through its one quarter turn of rotation. It contains gearing so that hundreds of turns of the motor or handwheel will slowly move the valve from open to close position in about 60 seconds or vice versa. Electrical controls are included in the motor actuator for local electrical control.

The output motion of the actuator is limited to about 100 degrees of output rotation by mechanical stops in the gearing. These are factory set and should not need adjustment. The actual positioning of the valve disc will be done by limit switches in the motor actuator. The switches are also set at the factory but adjustment is sometimes required if the motor unit is installed on a separate mounting base or floorstand. Detailed procedures are given in the motor manual if adjustment is needed for the mechanical stops or the limit switches. The wiring and power requirements are given on wiring diagrams included in this instruction manual.

# 24” and Larger Butterfly Valves

## Start-up / Maintenance

### START-UP PROCEDURE

#### Manual Operated Butterfly Valves

The manually operated valves should be fully cycled from close to open and back to the closed position to verify operation. Do not force the valve in the closed position if tight shutoff is not achieved; make adjustments to the operator per the maintenance instructions.

#### Cylinder Operated Butterfly Valves

For valves equipped with power cylinder actuators, connect the specified hydraulic pressure to the cylinder and controls. All hydraulic supplies must be filtered to prevent contamination and clogging of the controls. The valve can be cycled open and closed by powering the solenoid valves mounted on the cylinder.

#### Motor Operated Butterfly Valves

Refer to the motor actuator instruction manual for start-up information.

**⚠ WARNING: Do not remove the actuator with water in the pipe, or the valve may suddenly open and cause physical damage or personal injury.**

### MAINTENANCE

Maintenance of valves by owner is generally limited to actuators and shaft seals. In some instances, valve design permits field adjustment seats when leakage occurs. Unless the owner has skilled personnel and proper equipment, any major rework will require removal of the valve from the line. Depending on condition, valve may require return to the manufacturer.

#### Annual Maintenance

1. Cycle valve to verify operation and no interference in line.
2. Close valve and check for leakage. If leakage is found, check actuator stops to verify that the disc is fully closed. If leakage persists, remove valve to inspect seat. Contact Henry Pratt Company's Field Service Department for information regarding adjustment or replacement of seat.
3. Check flange connections for leakage. Tighten bolts accordingly.

4. Check top trunnion area for shaft leakage. If leakage is detected, replace valve packing.

5. If access to line is possible, then removal of scale that may interfere with the disc travel is suggested. The seat should be inspected for wear and taper pin nuts should be tight.

**⚠ WARNING: Removal of actuator from valve shaft will cause disc to rotate, striking persons or objects in the disc path, causing injury to persons and damage to valve. Block or lock disc before removing actuator.**

Typical maintenance would be shaft packing replacement and actuator adjustment. Seal leakage, broken parts and difficult operation should be discussed with Henry Pratt Company's Service Department before valve repairs are attempted.

Henry Pratt Company Service Engineers are available to perform or supervise valve repairs in the field.

Stop line flow and isolate from line pressure prior to performing any corrective maintenance.

After completing repair, cycle valve through one complete operating cycle and after line pressure has been restored, inspect for leakage.

#### Lubrication

No lubrication is required.

#### Spare Parts

Stocking of spare parts not recommended.

# 24” and Larger Butterfly Valves

## Troubleshooting

### TROUBLESHOOTING

PROBLEM	CAUSE	SOLUTION
Leakage between valve and actuator	<ul style="list-style-type: none"> <li>• Packing leak</li> </ul>	<ul style="list-style-type: none"> <li>• First, cycle the valve several times. This should adjust the packing. If this fails, clean packing bore and replace packing.</li> </ul>
Bottom trunnion leaks	<ul style="list-style-type: none"> <li>• Packing or gasket leak</li> </ul>	<ul style="list-style-type: none"> <li>• Replace bottom shaft packing, O-ring or gasket.</li> </ul>
Valve leaks when closed	<ul style="list-style-type: none"> <li>• Disc not fully closed or past fully closed</li> <li>• Disc edge wear or damage</li> <li>• Rubber seat wear or damage</li> </ul>	<ul style="list-style-type: none"> <li>• Adjust actuator closed position stop.</li> <li>• Clean and/or repair disc edge.</li> <li>• Adjust or replace valve seat*</li> </ul>
Chainwheel jams	<ul style="list-style-type: none"> <li>• Poorly fitting chain</li> </ul>	<ul style="list-style-type: none"> <li>• Replace with correct chain.</li> </ul>
Valve hard to operate	<ul style="list-style-type: none"> <li>• Foreign material in valve</li> <li>• Corroded actuator parts</li> <li>• Loose actuator</li> </ul>	<ul style="list-style-type: none"> <li>• Remove obstructions.</li> <li>• Clean and grease actuator.</li> <li>• Apply Loctite or Omnifit locking compound and tighten bolts.</li> </ul>
Automatic valve does not actuate	<ul style="list-style-type: none"> <li>• No power source</li> <li>• Improper signal</li> <li>• Burned out or impaired component</li> </ul>	<ul style="list-style-type: none"> <li>• Check incoming power source and replace fuses or reset pressure.</li> <li>• Check actuating signal sequence.</li> <li>• Check and repair or replace solenoids, motors and relay devices.</li> </ul>

\*Seat replacement should not be performed by untrained/unqualified personnel. In the event that seat replacement is needed, please contact Henry Pratt Company Field Service.

# 24" and Larger Butterfly Valves

## Replacement Procedure

### V-TYPE VALVE SHAFT PACKING REPLACEMENT

Your Pratt® Rubber Seat Butterfly Valve is equipped with a valve shaft packing gland located at the point where the shaft extends through the valve body.

The packing gland is non-adjustable. It consists of a set of V-type packing rings with the top and bottom

adapter ring held in place by the operator furnished on the valve.

This wear compensating V-type packing has a long service life, but should replacement be required, Henry Pratt Company's Service and Aftermarket departments can assist you. It is important to obtain

replacement packing that conforms to the nominal depth of the packing set as supplied. A deviation will result in pressure that might prevent the packing from functioning properly. Please contact our Aftermarket Department regarding obtaining replacement packing.

### REPLACING V-TYPE PACKING RUBBER SEAT BUTTERFLY VALVES

Before commencing any work on the valve, be sure the valve disc is isolated from any pressure and in the CLOSED POSITION. This prevents it from swinging freely when the operator is removed.

1. Remove the operator assembly or the packing retainer plate and expose the existing packing.
2. Remove old packing. A bent steel hook rod will assist in this operation.
3. Put in the new packing, one ring at a time, seating each firmly against the adjacent ring. Exercise extreme care in placing ring in packing bore so as not to damage the ring. The two sealing lips on the V-packing should be pointed toward the valve disc (see diagram on right).
4. Reassemble the operator or packing gland retainer plate.

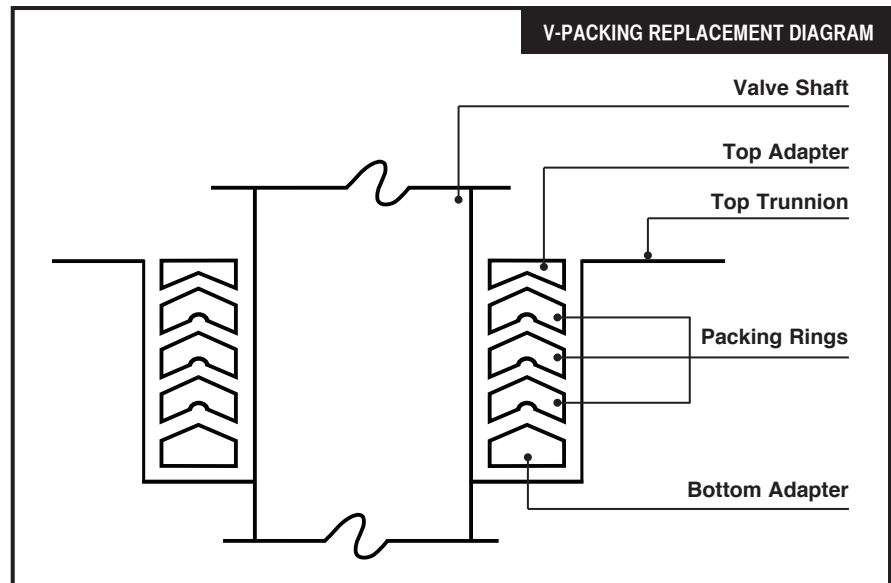

# 24" and Larger Butterfly Valves

## Parts Information

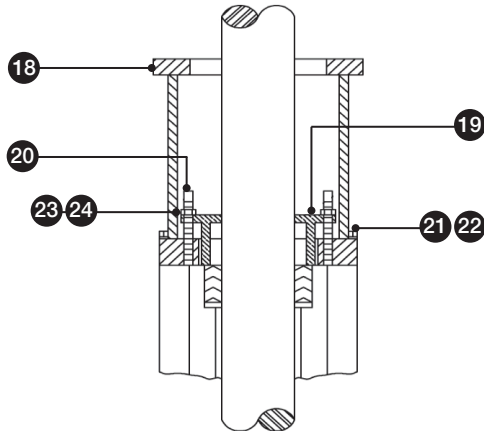

**OPTIONAL REPLACEABLE  
PACKING BONNET ASSEMBLY**

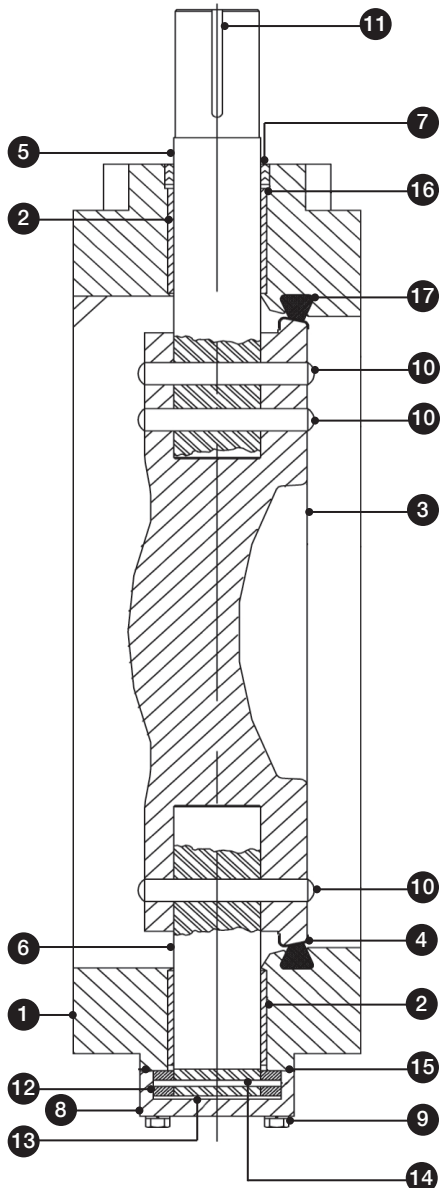

### 24" TRITON SERIES VALVES PARTS

ID	DESCRIPTION	MATERIAL
1	Body	Cast Iron ASTM A-126 Class B Ductile Iron ASTM A-536 (65-45-12)
2	Bearings	Teflon Lined, Fiberglass Backed
3	Disc	Ductile Iron ASTM A-536 (65-45-12)
4	Disc Edge	316 Stainless Steel ASTM A-240
5	Top Stub Shaft	304 Stainless Steel ASTM A-276 316 Stainless Steel ASTM A-276 Monel ASTM B-164 Alloy 400
6	Bottom Stub Shaft	304 Stainless Steel ASTM A-276 316 Stainless Steel ASTM A-276 Monel ASTM B-164 Alloy 400
7	Packing	Rubber (BUNA-N) Resiloseal W (EPDM)
8	Bottom Cover	Cast Iron ASTM A-126 Class B
9	Cap Screws	Carbon Steel 304 Stainless Steel 316 Stainless Steel
10	Squeeze Pins	304 Stainless Steel Astm A-276 316 Stainless Steel ASTM A-276 Monel ASTM B-164 Alloy 400
11	Key	Carbon Steel AISI 1045
12	Thrust Collar	Bronze ASTM B-505 Alloy C93200
13	Thrust Collar Shims	Brass Alloy C26000 Half Hard (HO2)
14	Spring Pin	Stainless Steel Type 420
15	O-Ring	Rubber (BUNA N)
16	Packing Retainer	Nylon
17	Seat	Resiloseal R (BUNA-N) Resiloseal W (EPDM)
18	Bonnet	Cast Iron ASTM A-48 Class 40
19	Packing Gland	Bronze ASTM B-584 Alloy C86400
20	Packing Gland Stud	304 Stainless Steel
21	Cap Screws	Carbon Steel
22	Lockwashers	Carbon Steel
23	Packing Gland Nut	304 Stainless Steel
24	Loctite	Grade Cv

TO ORDER: Contact our Parts Department.

Henry Pratt Company  
401 South Highland Avenue  
Aurora, IL 60506-5563  
Attn: Parts Manager  
(630) 844-4000

When ordering parts, please include the serial number located on the valve tag and description of part requested.



# 24" and Larger Butterfly Valves

## Parts Information

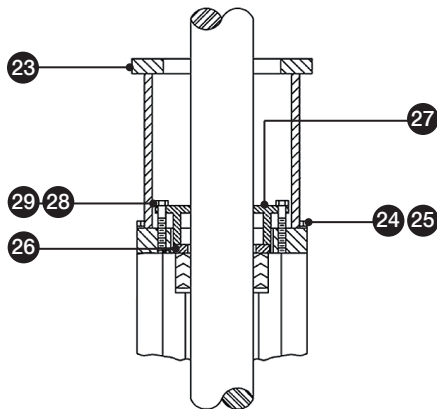

**OPTIONAL REPLACEABLE  
PACKING BONNET ASSEMBLY**

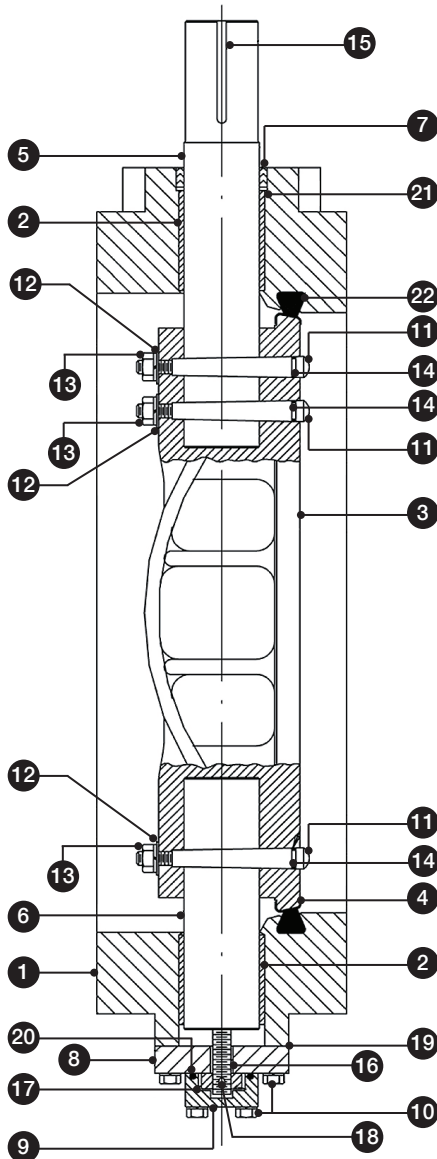

### 30" & LARGER TRITON SERIES VALVES PARTS

ID	DESCRIPTION	MATERIAL
1	Body	Cast Iron ASTM A-48 Class 40
		Cast Iron ASTM A-126 Class B
		Ductile Iron ASTM A-536 (65-45-12)
2	Bearings	Teflon Lined, Fiberglass Backed
3	Disc	Cast Iron ASTM A-48 Class 40
		Ductile Iron ASTM A-536 (65-45-12)
4	Disc Edge	316 Stainless Steel ASTM A-240
5	Top Stub Shaft	304 Stainless Steel ASTM A-276
		316 Stainless Steel ASTM A-276
		630 Stainless Steel ASTM A-564
6	Bottom Stub Shaft	304 Stainless Steel ASTM A-276
		316 Stainless Steel ASTM A-276
		630 Stainless Steel ASTM A-564
7	Packing	Rubber (BUNA-N)
		Rubber (EPDM)
8	Bottom Cover	Cast Iron ASTM A-126 Class B
		Ductile Iron ASTM A-536 (65-45-12)
9	Bottom Cover Cap	Cast Iron ASTM A-126 Class B
		Ductile Iron ASTM A-536 (65-45-12)
10	Cap Screws	Carbon Steel
		304 Stainless Steel
		316 Stainless Steel
11	Taper Pins	630 Stainless Steel ASTM A-564
12	Lockwashers	304 Stainless Steel
		316 Stainless Steel
13	Hex Nuts	304 Stainless Steel
		316 Stainless Steel
14	O-Rings	Rubber (BUNA-N)
		Rubber (EPDM)
15	Key	Carbon Steel AISI 1045
16	Thrust Bearing Stud	304 Stainless Steel ASTM A-276
		316 Stainless Steel ASTM A-276
		630 Stainless Steel ASTM A-564
17	Thrust Collar	Bronze ASTM B-505 Alloy C93200
18	Groove Pin	Alloy Steel
19	Bottom Cover Gasket	Non-Asbestos Material ASTM F104
20	O-Ring	Rubber (BUNA N)
		Rubber (EPDM)
21	Packing Retainer	Nylon
22	Rubber Seat	Resiloseal R (BUNA-N)
		Resiloseal Z (EPDM)
23	Bonnet	Cast Iron ASTM A-48 Class 40
24	Lockwashers	Carbon Steel
25	Cap Screws	Alloy Steel SAE GR 8
26	Packing Gland	Bronze SAE 660
27	Follower	Bronze ASTM B-504 Alloy C93200
28	Cap Screws	Carbon Steel
29	Lockwashers	Carbon Steel



**Reliable Connections<sup>®</sup>**

Henry Pratt Company  
1.630.844.4000  
[www.henrypratt.com](http://www.henrypratt.com)  
[moreinfo@henrypratt.com](mailto:moreinfo@henrypratt.com)

International  
1.423.490.9555  
[www.mueller-international.com](http://www.mueller-international.com)  
[international@muellercompany.com](mailto:international@muellercompany.com)

Copyright © 2017 Henry Pratt Company, LLC. All Rights Reserved.

The trademarks, logos and service marks displayed in this document herein are the property of Henry Pratt Company, LLC, its affiliates or other third parties. Products marked with a section symbol (§) are subject to patents or patent applications. For details, visit [www.mwppat.com](http://www.mwppat.com). These products are intended for use in potable water or wastewater applications. Please contact your Henry Pratt Company Sales or Customer Service Representative concerning any other application(s).

**Form 13801 - 01/17**