

VALVE SIZE	ORFICE SIZE	MAX C.W.P.	"A"	"B"	PRATT PN	WT (LBS)
1/2	1/16	175	4-3/4	6-1/8	WAR050505-116-175	6.3
3/4	1/16	175	4-3/4	6-1/8	WAR757505-116-175	6.3
1/2	3/32	175	5-1/8	6-7/8	WAR057505-332-175	8.2
1/2	1/16	300	5-1/8	6-7/8	WAR050505-116-300	8.2
1/2	1/16	300	5-1/8	6-7/8	WAR051005-116-300	8.2
3/4	3/32	175	5-1/8	6-7/8	WAR757505-332-175	8.2
3/4	1/16	300	5-1/8	6-7/8	WAR751005-116-300	8.2
1	1/16	300	5-1/8	6-7/8	WAR101005-116-300	8.2
3/4	1/8	150	6-1/8	7-7/8	WAR751005-018-150	12.4
3/4	3/32	300	6-1/8	7-7/8	WAR751005-332-300	12.4
1	1/8	150	6-1/8	7-7/8	WAR101005-018-150	12.4
1	3/32	300	6-1/8	7-7/8	WAR101005-332-300	12.4

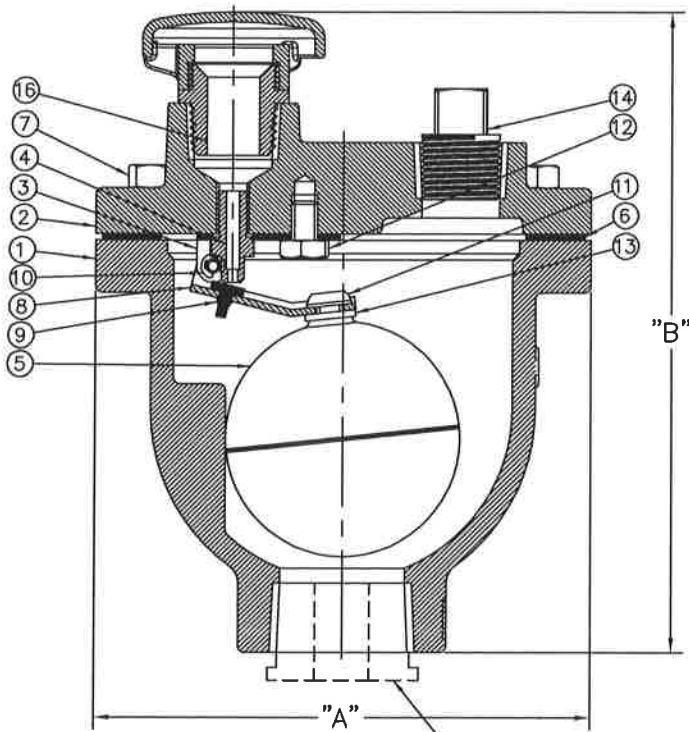

ITEM	DESCRIPTION	MATERIAL
1	BODY	DUCTILE IRON
2	COVER	DUCTILE IRON
3	LEVER BRACKET	STAINLESS STEEL
4	SEAT	STAINLESS STEEL
5	FLOAT	STAINLESS STEEL
6	GASKET	NON-ASBESTOS FIBER
7	COVER BOLT	STAINLESS STEEL
8	LEVER ARM	STAINLESS STEEL
9	BUTTON	BUNA-N OR EPDM
10	PIVOT PIN/RET. RING	STAINLESS STEEL
11	FLOAT TETAINER	STAINLESS STEEL
12	POSITIONER	STAINLESS STEEL
13	LOCK WASHER	STAINLESS STEEL
14	PIPE PLUG	STEEL OR STAINLESS STEEL
15	REDUCER BUSHING (IF REQ)	STAINLESS STEEL
16	VENT CAP	DUCTILE IRON

REDUCER BUSHING
REQUIRED ON SOME SIZES

01	4/4/16	JUR	REV. TABLE	JF
REV DATE	BY	DESCRIPTION	APP	
PRATT HENRY PRATT COMPANY AURORA, ILL.				
1/2" - 1" SIMPLE LEVER WATER AIR RELEASE VALVE				
SCALE	NONE	DATE	3/25/16	
DRAWN BY	JUR	CHECKED BY	RF	
APPROVED		GA=BORDER		
DRWG. NO.	GA-12310	REV 1		1/3