

Series WAR 02 Air Release Valves – Compound Lever

Valve Size	Outlet Size	Orifice Size	Max C.W.P.	Inlet Connection	W	H	HC	Pratt Model #	Wt. (Lbs.)
1"	1/2"	3/16"	150	NPT	7"	10"	10-13/16"	WAR-101005-316-150	23.3
1"	1/2"	5/32"	300	NPT	7"	10"	10-13/16"	WAR-101005-532-300	23.3
2"	1/2"	3/16"	150	NPT	7"	10"	10-13/16"	WAR-202005-316-150	23.3
2"	1/2"	5/32"	300	NPT	7"	10"	10-13/16"	WAR-202005-532-300	23.3
2"	1"	23/64"	150	NPT	9-1/2"	12-1/4"	13-11/32"	WAR-202010-2364-150	48.1
2"	1"	7/32"	300	NPT	9-1/2"	12-1/4"	13-11/32"	WAR-202010-732-300	48.1
3"	1"	23/64"	150	NPT	9-1/2"	12-1/4"	13-11/32"	WAR-303010-2364-150	48.1
3"	1"	7/32"	300	NPT	9-1/2"	12-1/4"	13-11/32"	WAR-303010-732-300	48.1

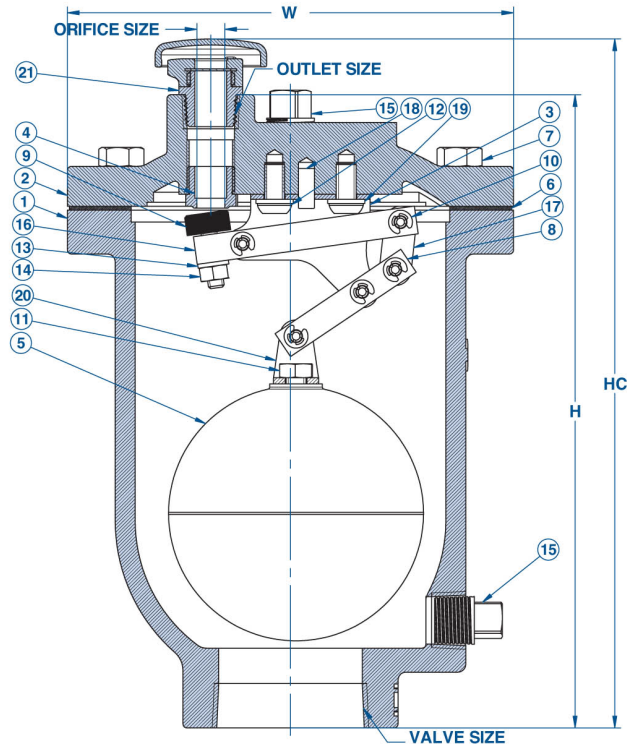

Part #	Description	Material
1	Body	ASTM A536 65-45-12
2	Cover	ASTM A536 65-45-12
3	Lever Bracket	ASTM A240 316SS
4	Seat	ASTM A582 316SS
5	Float	ASTM A240 316SS
6	Gasket	Non-Asbestos Fiber
7	Cover Bolt	ASTM F593 316SS
8	Short Lever Arm	ASTM A582 316SS
9	Button	Stainless Steel & Buna-N
10	Pivot Pin & Retaining Ring	Stainless Steel
11	Float Retainer	ASTM F593 316SS
12	Positioner	ASTM F879 316SS
13	Lock Washer	ASTM A240 316SS
14	Lock Nut	ASTM F594 316SS
15	Pipe Plug	Steel
16	Long Lever Arm	ASTM A582 316SS
17	Arm Link	ASTM A240 316SS
18	Positioning Pin	420SS
19	Lock Washer	ASTM A240 316SS
20	Clevis	ASTM A240 316SS
21	Vent Cap	ASTM A536 65-45-12