

VALVE SIZE	A	B	C	D
3	4-3/4	3-1/4	5-1/4	2-1/16
4	5-1/2	3-1/2	6-3/4	2-5/16
6	6-1/2	5-1/8	8-5/8	2-15/16
8	7-3/4	6-1/2	10-7/8	3-1/16
10	9	9-7/8	13-1/4	3-3/16
12	10-1/2	11-3/8	16	3-7/16
14	11-7/8	12-5/8	17-5/8	3-11/16
16	13-1/2	14-1/2	20-1/8	4-3/16

MODEL	J	M	P	R	S	V
504	11-1/2	8-1/2	3	8-1/8	15	6-3/8
524	12-3/8	9-1/4	3-3/4	8-1/8	15	6-3/8

WIRING DIAGRAM	
MODEL	DRAWING NO.
504/524	GA-11650

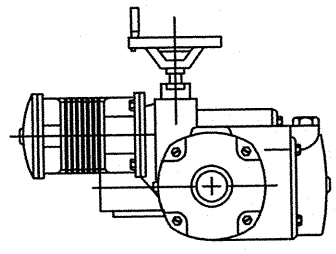
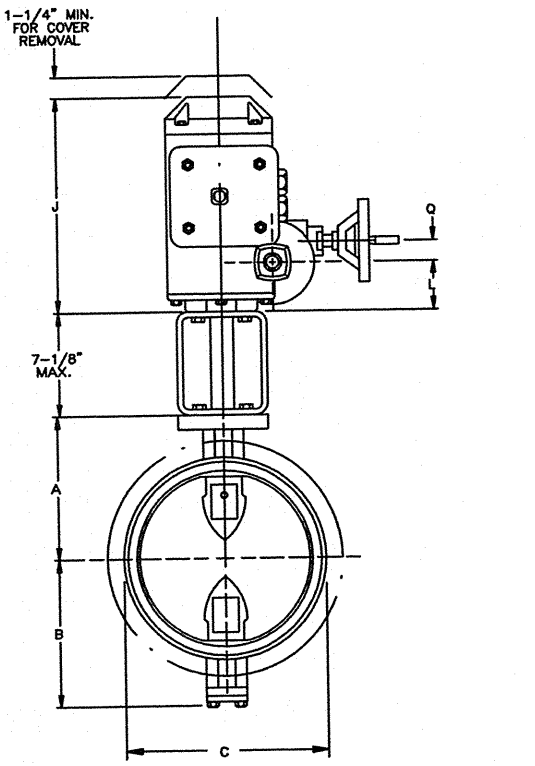

POSITION 02

NOTE: DIMENSION "C" ALLOWS CLEARANCE FOR 150 LB OR 125 LB A.S.A. BOLT LAYOUT.

- NOTES:
- ALL DIMENSIONS SHOWN IN INCHES. "D" DIMENSION 1/16" FOR 3" THRU 10" VALVES. "D" DIMENSION 1/8" FOR 12" THRU 16" VALVES.
  - VALVES MANUFACTURED AND TESTED IN ACCORDANCE WITH AWWA SPECIFICATIONS C-504-LATEST, CLASS 150B. SUPPLIED WITH (2) 3/4" NPT CONDUIT ENTRIES.
  - MUST USE CONTROL PANEL STATION P/N: 2324247 FOR LOCAL CONTROL.

REV	DATE	BY	DESCRIPTION	APP
△	06/24/13	JTC	ADDED NOTE 4	bcg
△	03/19/07	ES	UPDATED WIRING DIAGRAM	PPS

**PRATT** HENRY PRATT COMPANY  
AURORA, ILL.

GENERAL ARRANGEMENT DRAWING  
MONOFLANGE MARK II BUTTERFLY VALVE  
POSITION II BASIC OPEN/CLOSE

SCALE NONE DATE 6/9/06

DRAWN BY SR CHECKED BY JR

APPROVED GA-BORDER

DRWS. NO. GA-11582 REV 2 A/c