

| VALVE SIZE | A | B | C | D | E | F | G |
|------------|--------|--------|--------|---|--------|---------|--------|
| 3 | 4-3/4 | 3-1/4 | 7-1/2 | 5 | 3/4 | 4--5/8 | 6 |
| 4 | 5-1/2 | 3-1/2 | 9 | 5 | 15/16 | 8--5/8 | 7-1/2 |
| 6 | 6-1/2 | 5-1/8 | 11 | 5 | 1 | 8--3/4 | 9-1/2 |
| 8 | 7-3/4 | 6-1/2 | 13-1/2 | 6 | 1-1/8 | 8--3/4 | 11-3/4 |
| 10 | 9 | 9-7/8 | 16 | 8 | 1-3/16 | 12--7/8 | 14-1/4 |
| 12 | 10-1/2 | 11-3/8 | 19 | 8 | 1-1/4 | 12--7/8 | 17 |
| 14 | 11-7/8 | 12-5/8 | 21 | 8 | 1-3/8 | 12--1 | 18-3/4 |
| 16 | 13-1/2 | 14-1/2 | 23-1/2 | 8 | 1-7/16 | 16--1 | 21-1/4 |

| MODEL | J | M | P | R | S | V |
|---------|--------|-------|-------|--------|----|-------|
| 504,704 | 11-1/2 | 8-1/2 | 9-1/4 | 13-3/4 | 15 | 6-3/8 |
| 524,724 | 12-3/8 | 9-1/4 | 9-1/4 | 13-3/4 | 15 | 6-3/8 |

| WIRING DIAGRAM | |
|----------------|-------------|
| MODEL | DRAWING NO. |
| 504/524 | GA-11651 |
| 704/724 | GA-11654 |

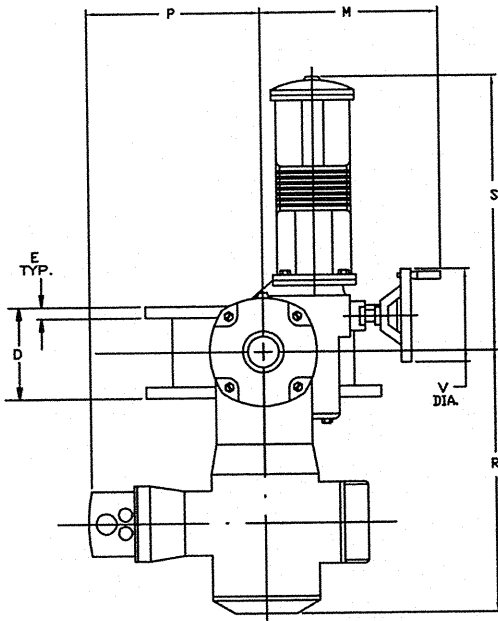

POSITION 01

1-1/4" MIN. FOR COVER REMOVAL

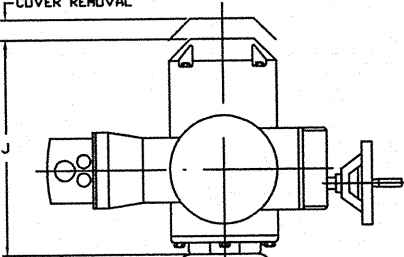

POSITION 02

7-1/8" MAX.

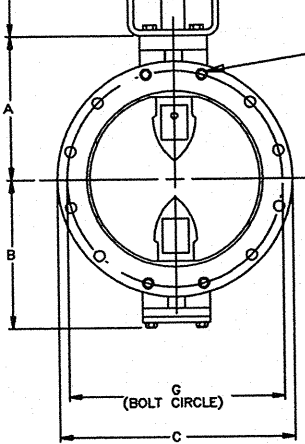

F=NO. & SIZE OF BOLTS (125# STD. LAYOUT STRADDLE CENTERLINE) FLANGE BOLT HOLES ARE 1/8" LARGER THAN BOLT DIAMETER
NOTE: CAST STEEL BODIES HAVE 4 TAPPED HOLES "F" UNC-2B X E DEEP PER FLANGE. 2 HOLES AT TOP AND 2 HOLES AT BOTTOM AS SHOWN.

NOTES:

- ALL DIMENSIONS SHOWN IN INCHES. "D" DIMENSION $\pm 1/16"$.
- DIMENSIONS AND DRILLING OF END FLANGES CONFORM TO THE AMERICAN CAST IRON FLANGE STANDARDS, CLASS 125 (B16.1).
- (RECOMMENDATIONS FOR MATING FLANGES) WHERE INSULATING BUSHINGS ARE USED, IT IS NECESSARY THAT BOLT HOLES BE DRILLED OVERSIZE BY AN AMOUNT EQUAL TO TWO TIMES THE INSULATING SLEEVE THICKNESS TO MAINTAIN THE SAME MINIMUM CLEARANCE FOR BOLTS.
- VALVES MANUFACTURED AND TESTED IN ACCORDANCE WITH AWWA SPECIFICATIONS C-504-LATEST, CLASS 150B.
- SUPPLIED WITH (2) 3/4" NPT CONDUIT ENTRIES.

| REV | DATE | BY | DESCRIPTION | APP |
|-----|----------|-----|------------------------------|-----|
| △ | 06/25/13 | JTC | UPDATED TITLE, MODEL DMS | RCB |
| △ | 03/15/07 | ES | UPDATE WIRING DIAGRAMS | PPS |
| △ | 10/29/06 | SR | REMOVED MAT'L AND PAINT INFO | PPS |

PRATT HENRY PRATT COMPANY
AURORA, ILL.

GENERAL ARRANGEMENT DRAWING
2F2 BUTTERFLY VALVE WITH
POSITION II & III WITH
PUSHBUTTONS

SCALE NONE DATE 6/11/06

DRAWN BY SR CHECKED BY JR

APPROVED GA=BORDER

DRWC. NO. GA-11588 REV 3 ¹/_C

