

ACTUATOR SIZE	J	L	M	N	P	Q	R	NUMBER OF TURNS
MDT-4S	6-3/8	2-27/32	3-3/8	4	7-5/16	6-3/4	11-5/16	40
MDT-5	7-9/16	3-15/32	4-1/2	5-1/2	8-3/4	10-7/16	17	44
MDT-5S	8-5/16	3-15/16	5-5/8	3-5/8	10-5/8	15-15/16	19-7/8	136
MDT-6S	10-3/16	5-1/16	7	8-1/4	12-5/8	18-5/8	26-1/2	215

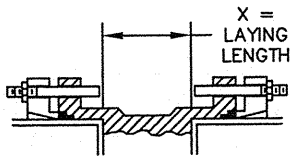

INSTALLATION DIAGRAM
BOLTS, NUTS, GLANDS
AND GASKETS FURNISHED
BY OTHERS

VALVE SIZE	A	B	C	D	E	F	G	X
24	18-5/8	18-5/8	31-9/16	13-1/4	1-5/8	16--3/4	30	6-3/8
30	21-1/2	24-3/8	39	18	1-13/16	20--1	36-7/8	10
36	25-7/16	28-1/4	45-7/8	22	2	24--1	43-3/4	14
42	29-7/8	32-7/8	53	22	2	28--1-1/4	50-5/8	14
48	34-1/16	37-1/8	59-7/8	24	2	32--1-1/4	57-1/2	16

3-1/2 SPACE REQUIRED
FOR THRUST BEARING
COVER REMOVAL

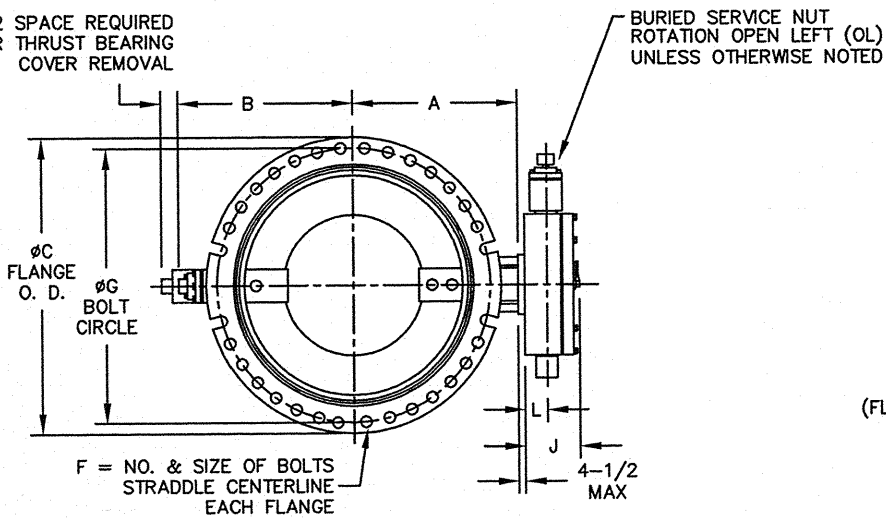

SPUR GEAR FURNISHED
ON MDT-6S

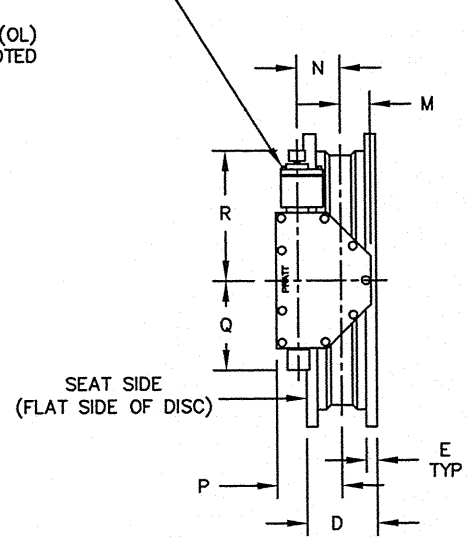

ACTUATOR POSITION 1

NOTES:

- ALL DIMENSIONS SHOWN IN INCHES. "D" DIMENSION $\pm 1/8$ " BOLT HOLES WILL BE $1/8$ " LARGER THAN DIAMETER OF BOLT
- DIMENSIONS AND DRILLING OF MECHANICAL JOINT ENDS CONFORM TO ANSI AWWA C111 A21.11.
- CAUTION:
IT IS RECOMMENDED THAT VALVES BE INSTALLED INTO THE PIPING SYSTEM IN ACCORDANCE WITH AWWA M-11 IN ORDER TO PREVENT ANY UNDUE PIPING STRESS, DEFLECTION OR BENDING THAT MAY AFFECT THE PERFORMANCE OF THE VALVE.

REV	DATE	DESCRIPTION	DWN	APP
2	12/16/16	REVISED MDT-4S REVISED MDT-5 REVISED MDT-5S REVISED MDT-6S	JWD	RF
1	4/18/06	REMOVED MDT-2S & 3S	BB	JR

PRATT

HP250II MJE
24" THRU 48"
MDT BURIED SERVICE ACTUATOR

SCALE	NONE	DATE	1/13/05
DRAWN BY	BZ	CHECKED BY	ES
APPROVED	GA=BORDER		
DRWG. NO.	GA-11362	REV	2