

ACTUATOR SIZE	VALVE SIZE	J	L	M	N	P	Q	R	S	T	V	W	NUMBER OF TURNS
MDT-2S	3-8"	4-11/16	2	2-1/8	2	4-1/2	4-1/4	8-1/4	7-7/8	7-7/8	8	9-1/8	32
MDT-3S	10-14"	5-5/8	2-7/16	3-1/4	3-5/32	5-5/8	5-3/8	10-3/8	10-1/2	10-1/8	12	9-1/8	30
MDT-4S	16 & 18"	6-3/8	2-27/32	3-3/8	4	7-5/16	6-3/4	11-5/16	11-1/2	11	12	9-1/8	40
MDT-5	20"	7-9/16	3-15/32	4-1/2	5-1/2	8-3/4	10	17	17 3/16	17-3/16	18	16-7/16	44

VALVE SIZE	A	B	C	D	E	F	G
3	4-3/4	3-1/4	7-1/2	5	13/16	4--5/8	6
4	5-1/2	3-1/2	9	5	1	8--5/8	7-1/2
6	6-1/2	5-1/8	11	5	1-1/16	8--3/4	9-1/2
8	7-3/4	6-1/2	13-1/2	6	1-3/16	8--3/4	11-3/4
10	9	9-11/16	16	8	1-3/16	12--7/8	14-1/4
12	10-1/2	11-3/16	19	8	1-5/16	12--7/8	17
14	11-7/8	12-5/8	21	8	1-3/8	12--1	18-3/4
16	13-1/2	14-3/8	23-1/2	8	1-7/16	16--1	21-1/4
18	14-3/8	15-1/4	25	8	1-9/16	16--1-1/8	22-3/4
20	16	16-7/8	27-1/2	8	1-11/16	20--1-1/8	25

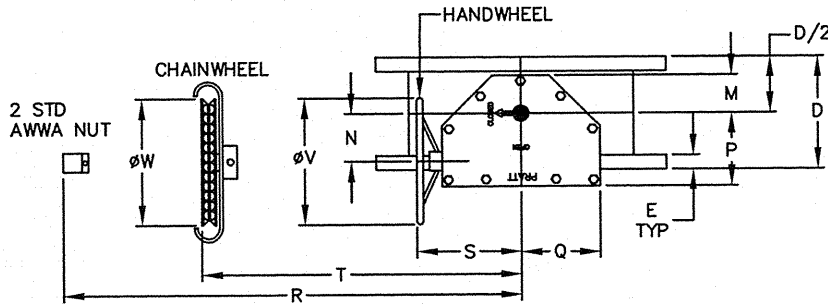

ACTUATOR POSITION 1

NOTES:

1. ALL DIMENSIONS SHOWN IN INCHES.
2. "D" DIMENSION  $\pm 1/16$ " FOR 3" THRU 10" VALVES.  
"D" DIMENSION  $\pm 1/8$ " FOR 12" THRU 20" VALVES.
3. FLANGE THROUGH BOLT HOLES WILL BE  $1/8$ " LARGER THAN DIAMETER OF BOLT.
4. DIMENSIONS AND DRILLING OF END FLANGES CONFORM TO THE AMERICAN CAST IRON FLANGE STANDARDS, CLASS 125 (B16.1).
5. VALVES MANUFACTURED & TESTED IN ACCORDANCE WITH AWWA SPECIFICATION C-504 LATEST REVISION, CLASS 250B.
6. RECOMMENDATION FOR MATING FLANGES: WHERE INSULATING BUSHINGS ARE USED, IT IS NECESSARY THAT BOLT HOLES BE DRILLED OVERSIZE BY AN AMOUNT EQUAL TO TWO TIMES THE INSULATING SLEEVE THICKNESS TO MAINTAIN THE SAME MINIMUM CLEARANCE FOR BOLTS.

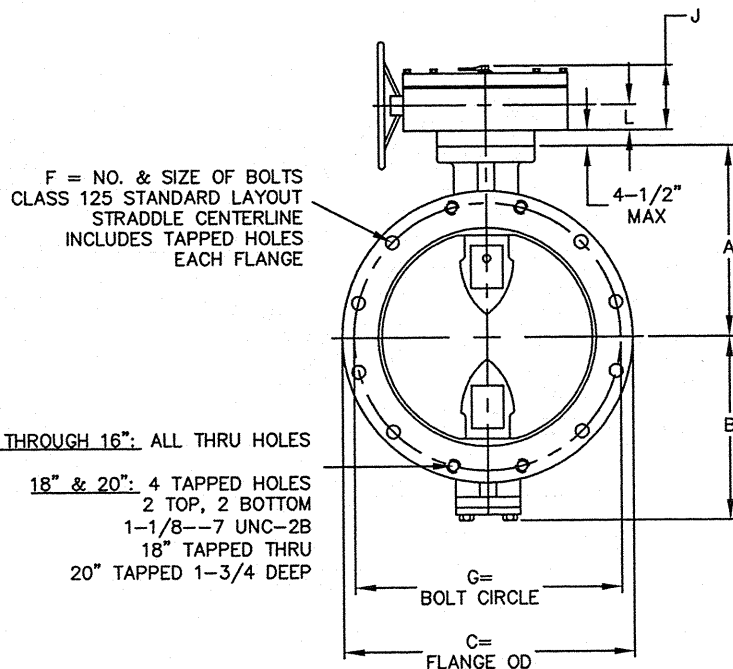

TOLERANCES	
FLANGE THICKNESS "E":	$+1/8$ 0
LAYING LENGTH "D":	
3" THRU 10"	$\pm 1/16$ "
12" THRU 20"	$\pm 1/8$ "
BOLT CIRCLE "G":	$\pm 1/64$ "
FLANGE O.D. "C":	
3" THRU 10"	$\pm 1/8$ "
12" THRU 20"	$\pm 3/16$ "

3 THROUGH 16": ALL THRU HOLES

18" & 20": 4 TAPPED HOLES  
2 TOP, 2 BOTTOM  
1-1/8--7 UNC-2B  
18" TAPPED THRU  
20" TAPPED 1-3/4 DEEP

REV	DATE	DESCRIPTION	BY	APP
4	12/15/06	UPDATED TITLE BLOCK	JWD	JF
3	4/04/11	REVISE COLUMN "E" TOL.	JLM	ROB
2	10/06/09	REVISE COLUMN "B"	SK	ROB
1	9/02/09	CORRECT & UPDATE	CEM	JR

**PRATT**

3"-20" BONDED SEAT HP250II  
ANSI 125# FLG  
MDT MANUAL

SCALE	NONE	DATE	9/9/05
DRAWN BY	ES	CHECKED BY	JR
APPROVED	GA=BORDER		
DRWG. NO.	GA-11478	REV	4