

VALVE SIZE	A	B	C	CC	D	DD	E	EE	F	FF	G	GG	X
6	6-1/2	5-1/8	11	11	6-3/4	4-1/4	1-1/16	1-1/16	8--3/4	6--3/4	9-1/2	9-1/2	4-1/4
8	7-3/4	6-1/2	13-1/2	13-1/4	7-5/16	4-5/16	1-1/8	1-1/8	8--3/4	6--3/4	11-3/4	11-3/4	4-13/16
10	9	9-7/8	16	15-9/16	9	5	1-1/4	1-3/16	12--7/8	8--3/4	14-1/4	14	6-1/2
12	10-1/2	11-3/8	19	17-15/16	9-1/4	5-1/4	1-1/4	1-1/4	12--7/8	8--3/4	17	16-1/4	6-3/4
14	11-7/8	12-3/4	21	20-5/16	9-3/4	5-3/4	1-3/8	1-5/16	12--1	10--3/4	18-3/4	18-3/4	6-1/4
16	13-1/2	14-3/8	23-1/2	22-9/16	10	6	1-7/16	1-3/8	16--1	12--3/4	21-1/4	21	6-1/2
18	14-3/8	15-1/4	25	24-11/16	10-1/8	6-1/8	1-9/16	1-7/16	16--1-1/8	12--3/4	22-3/4	23-1/4	6-5/8
20	16	16-7/8	27-1/2	27-3/32	10-1/4	6-1/4	1-11/16	1-1/2	20--1-1/8	14--3/4	25	25-1/2	6-3/4

ACTUATOR SIZE	J	L	M	N	P	Q	R	NUMBER OF TURNS
MDT-2S	4-11/16	2	2-1/8	2	4-1/2	4-1/2	8-1/4	32
MDT-3S	5-5/8	2-7/16	3-1/4	3-5/32	5-5/8	5-3/8	10-3/8	30
MDT-4S	6-3/8	2-27/32	3-3/8	4	7-5/16	6-3/4	11-5/16	40
MDT-5	7-9/16	3-15/32	4-1/2	5-1/2	8-3/4	10	17	44

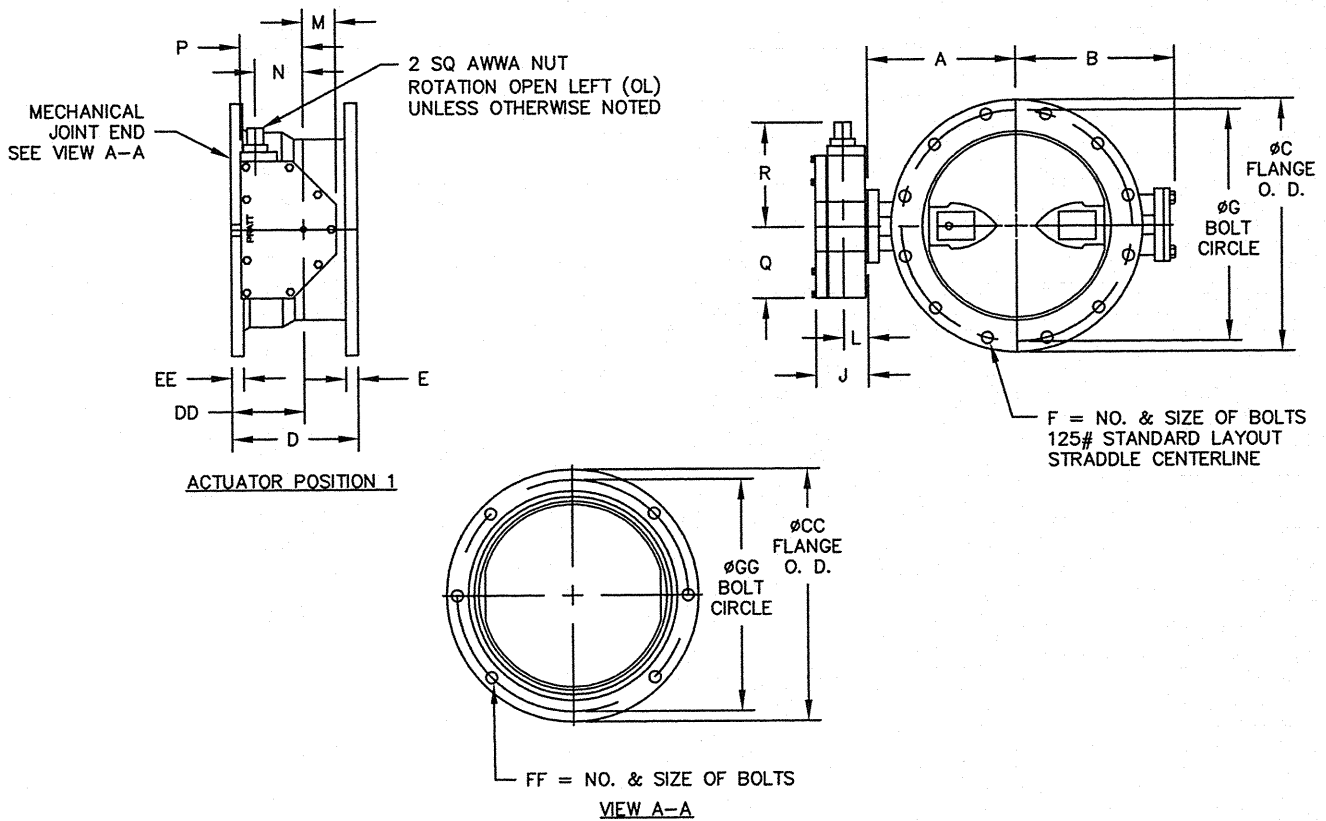

NOTES:

- ALL DIMENSIONS SHOWN IN INCHES.
- "D" DIMENSION  $\pm 1/16$ " FOR 6" THRU 10" VALVES.  
"D" DIMENSION  $\pm 1/8$ " FOR 12" THRU 20" VALVES.
- FOR BOLTS SMALLER THAN  $\phi 1-3/4$ , BOLT HOLES WILL BE  $1/8$ " LARGER THAN DIAMETER OF BOLT.  
FOR BOLTS  $\phi 1-3/4$  OR LARGER, BOLT HOLES WILL BE  $1/4$ " LARGER THAN DIAMETER OF BOLT.
- DIMENSIONS AND DRILLING OF END FLANGE CONFORM TO THE AMERICAN CAST IRON FLANGE STANDARDS, CLASS 125 (B16.1).
- DIMENSIONS AND DRILLING OF MECHANICAL JOINT END CONFORM TO ANSI/ AWWA C111/ A21.11.
- VALVES MANUFACTURED & TESTED IN ACCORDANCE WITH AWWA SPECIFICATION C-504 LATEST REVISION, CLASS 250B.
- RECOMMENDATION FOR MATING FLANGES: WHERE INSULATING BUSHINGS ARE USED, IT IS NECESSARY THAT BOLT HOLES BE DRILLED OVERSIZE BY AN AMOUNT EQUAL TO TWO TIMES THE INSULATING SLEEVE THICKNESS TO MAINTAIN THE SAME MINIMUM CLEARANCE FOR BOLTS.

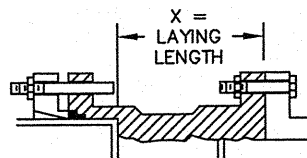

INSTALLATION DIAGRAM  
BOLTS, NUTS, GLANDS  
AND GASKETS FURNISHED  
BY OTHERS

REV	DATE	DESCRIPTION	BY	APP
3	12/27/16	REVISED 10" Ø "D", "DD", "X" REVISED 12" Ø "D", "DD", "X"	JWD	RF
2	5/15/08	ADDED 14", 18" & 20" ADDED MDTs	ES	CEM
1	4/18/06	ADDED ROTATION NOTE	BB	JR

**PRATT**

6"-20" HP250II GROUNDHOG VALVE  
FLANGE X MECHANICAL JOINT ENDS  
MDT BURIED SERVICE NUT

SCALE	NONE	DATE	12/15/05
DRAWN BY	RCB	CHECKED BY	PPS
APPROVED	GA-BORDER		
DRWG. NO.	GA-11515	REV	3