

VALVE SIZE	A	B	C	D*	E	F	G	X	ACT. SIZE
4	5-1/2	3-1/2	9	8-1/8	1	4--3/4	7-1/2	3-1/8	2S Δ
6	6-1/2	5-1/8	11	8-1/2	1-1/16	6--3/4	9-1/2	3-1/2	2S Δ
8	7-3/4	6-1/2	13-1/4	8-5/8	1-1/8	6--3/4	11-3/4	3-5/8	2S Δ
10	9	9-3/4	15-9/16	10	1-3/16	8--3/4	14	5	2S
12	10-1/2	11-3/8	17-15/16	10-1/2	1-1/4	8--3/4	16-1/4	5-1/2	2S
14	11-7/8	12-3/4	20-5/16	11-1/2	1-5/16	10--3/4	18-3/4	4-1/2	3S
16	13-1/2	14-1/2	22-9/16	12	1-3/8	12--3/4	21	5	3S
18	14-3/8	15-3/8	24-11/16	12-1/4	1-3/8	12--3/4	23-1/4	5-1/4	4S
20	16	17	27-3/32	12-1/2	1-1/2	14--3/4	25-1/2	5-1/2	5
24	18-5/8	18-5/8	31-9/16	13-1/4	1-5/8	16--3/4	30	6-3/8	5
30	21-1/2	24-3/8	39	18	1-13/16	20--1	36-7/8	10	5 Δ
36	25-7/16	28-1/4	45-7/8	22	2	24--1	43-3/4	14	5S Δ
42	29-7/8	32-7/8	53	22	2	28--1-1/4	50-5/8	14	6S Δ
48	34-1/16	37-1/8	59-7/8	24	2	32--1-1/4	57-1/2	16	6S Δ

ACTUATOR SIZE	J	L	M	N	P	Q	R	Y	NUMBER OF TURNS
MDT-2S	4-3/8	2	2-1/8	2	4-1/2	4-1/4	7-5/8	4-1/2	32
MDT-3S	5-1/8	2-7/16	3-1/4	3-5/32	5-5/8	5-7/16	9-3/8	6-5/8	30
MDT-4S	5-7/8	2-27/32	3-3/8	4	7-5/16	6-3/4	10-5/8	7-5/8	40
MDT-5	7-1/2	3-15/32	4-1/2	5-1/2	8-3/4	10-1/8	17	13-1/2	44
Δ MDT-5S	8-1/2	3-15/16	5-1/2	7	10-1/2	15-15/16	19-7/8	15-11/16	136
Δ MDT-6S	11	5-1/16	7	8-1/4	12-5/8	19	26-1/2	22-1/4	215

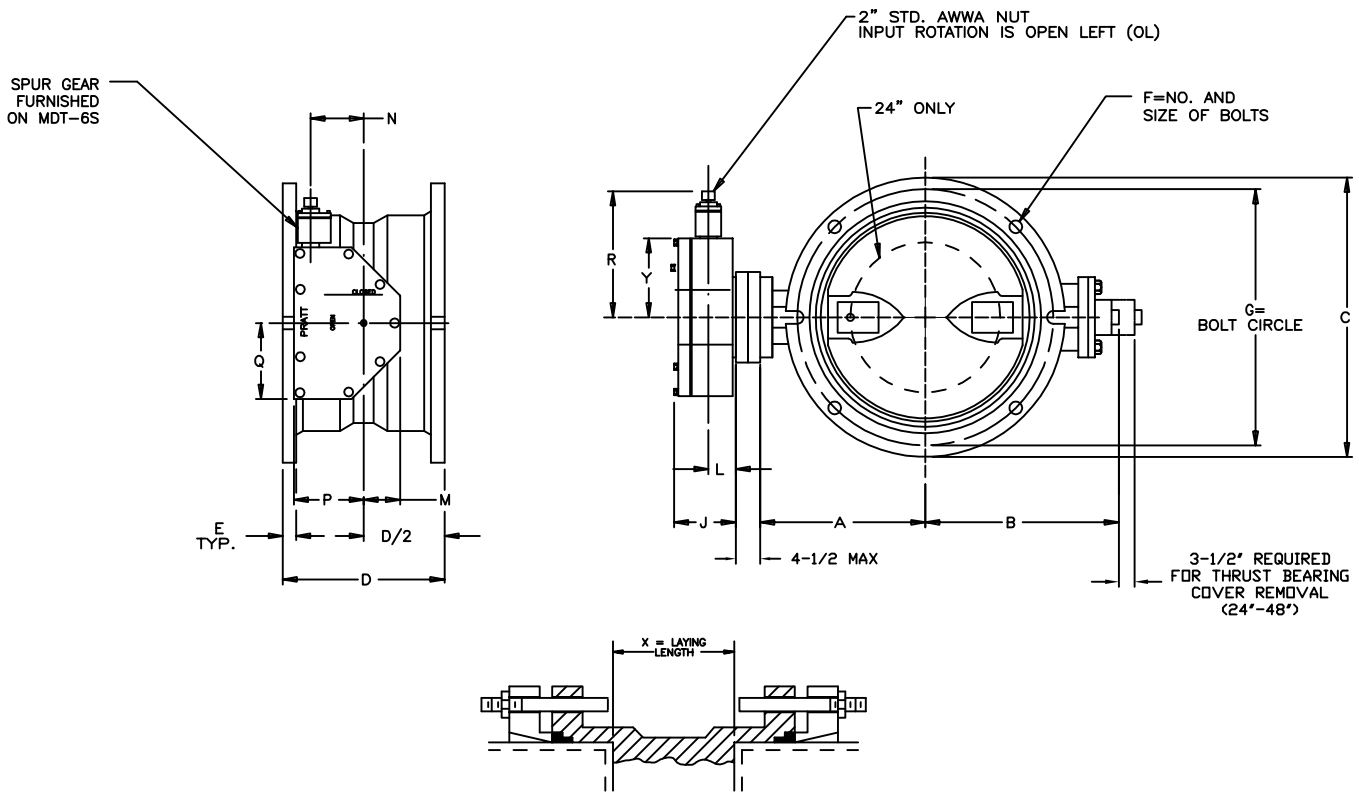

INSTALLATION DIAGRAM
NOTE: BOLTS, NUTS, GLANDS AND GASKETS FURNISHED BY OTHERS.

EXTERNAL DISTRIBUTION			
UL			

NOTES:

- *ALL DIMENSIONS SHOWN IN INCHES. "D" DIMENSION $\pm 1/16$ " THROUGH 10" VALVES, $\pm 1/8$ " FOR 12" AND LARGER VALVES.
- ACTUATOR MOUNTED IN POSITION AS SHOWN.
- FOR USE WITH BUTTERFLY VALVE INDICATOR POST-STYLE G.
- VALVES MANUFACTURED IN ACCORDANCE WITH UNDERWRITERS LABORATORIES STANDARD UL-1091, LATEST EDITION.
- Δ CAUTION: IT IS RECOMMENDED THAT VALVES BE INSTALLED INTO PIPING SYSTEM IN ACCORDANCE WITH AWWA M-11 TO PREVENT ANY UNDUE PIPING STRESS, DEFLECTION, OR BENDING THAT MAY EFFECT THE PERFORMANCE OF THE VALVE.
- Δ VALVES MANUFACTURED AND TESTED IN ACCORDANCE WITH AWWA SPECIFICATION C-504 LATEST REVISION, CLASS 150B.
- DIMENSIONS AND DRILLING OF END FLANGES CONFORM TO THE ANSI/AWWA C111/A21.11.

4	6-5-12	JTC	ADDED DIMS FOR 30"-48"	
3	11-21-11	CEM	CORRECTED DIMENSIONS	JLI
2	1-22-09	CEM	CORRECTED MDT SIZE WAS 15M	JR
1	10/29/06	SR	REMOVED MAT'L AND PAINT INFO	CEG
REV	DATE	BY	DESCRIPTION	APP.

PRATT HENRY PRATT COMPANY
AURORA, ILL.

GENERAL ARRANGEMENT DRAWING
GROUNDHOG VALVE
MECHANICAL JOINT ENDS
MDT ACTUATOR
UL LISTED

SCALE	NONE	DATE	6/12/06
DRAWN BY	SR	CHECKED BY	JR
APPROVED	GA=BORDER		
DRWG. NO.	GA-11603	REV	4